

LINN HELIX
OWNERS MANUAL

INTRODUCTION Thank you for choosing our Linn HELIX LS150 Loudspeakers, the result of extensive design and development work. The HELIX set new standards of performance in loudspeakers of this type.

Remember, no loudspeaker is capable of improving the quality of the input signal so the HELIX should be used with good quality ancillary equipment.

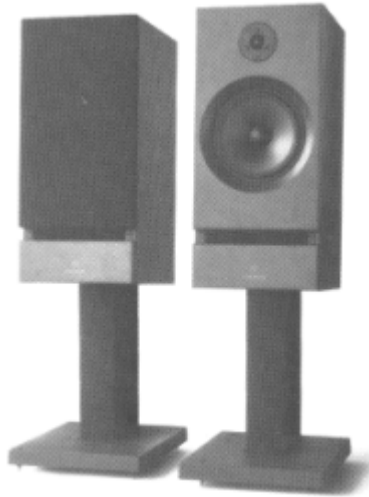

INSTALLATION Before unpacking the speakers, please remove all staples from the carton to avoid possible damage to the cabinets.

When removing the loudspeakers from their boxes, lift the cabinets out by their sides. This will avoid possible damage to the grilles and their drive units.

Please retain all packing for possible future transportation.

STANDS

All loudspeakers perform best when rigidly mounted. To achieve this, Linn have designed a stand for the HELIX, which includes stabilising floor spikes. These stands give optimum sound quality and ensure that the drive units are correctly positioned for the listener.

CONNECTIONS

Connection of the loudspeakers to the amplifier should be made with a good quality cable. Linn K20 loudspeaker cable is ideal, the leads should be terminated with the connectors supplied to ensure optimum performance. The use of other connectors will degrade the sound quality of your system.

The cable is marked with the Linn symbol to indicate directionality. The bare wires shown should be connected to the amplifier and the end marked with the circular logo should be connected to the loudspeakers.



< LOUDSPEAKERS

AMPLIFIER >

Take care to ensure that the wiring is correct. The red socket is positive and the black is negative. The positive wire (red connector) is identified by a rib along the side of the cable.

POSITIONING

HELIX speakers are designed to perform best when placed close to a wall. Ideally the rear of the loudspeaker should be between 4" and 12" (10 and 30cm) from the wall and at least 18" (45cm) from any corner.

HELIX can also benefit from being angled inward slightly by 5 to 10 degrees.

These are general guidelines and a little experimentation with positioning will optimise results for a particular room, your dealer will be pleased to do this when he installs your equipment.

GRILLE

The HELIX grille is special because it mounts directly onto the front fascia of the speaker. This avoids the problems of diffraction produced by conventional grille frames.

To remove the grille cloth, hold the fascia with both hands behind the groove in the middle of the vertical sides and pull forward until it is free from the wooden baffle behind.

To detach the grille cloth, gently pull its elastic edge over one corner of the fascia and then slowly and carefully detach the rest.

To re-assemble, reverse the process and re-attach the moulded fascia to the speaker by lining up and locating the lugs to their inserts on the wooden baffle and push home firmly until the fascia is flush with the tweeter.

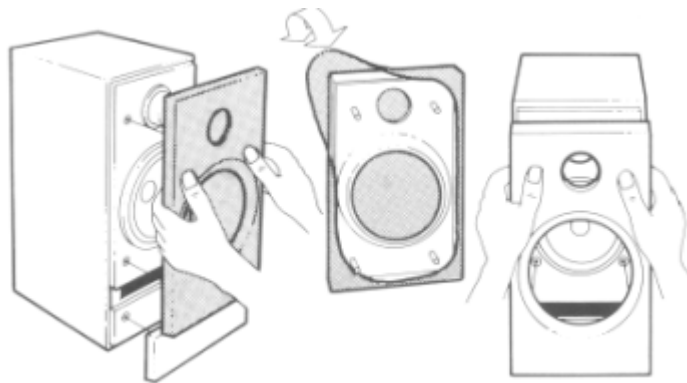

If the separate, smaller section of the fascia shifts during this operation, it should be firmly pushed back home. To re-fit the grille cloth, reverse the above procedure.

BI-WIRING

Bi-wiring improves the performance of a loudspeaker. By using a separate cable for the bass and treble section some interaction between the bass and treble section is removed. The extra cost of an additional pair of loudspeaker cables is more than justified by the improvement in sound quality gained.

To convert the HELIX to bi-wired mode, use the key provided to unscrew the negative (black) socket caps and remove the link. Replace and tighten the caps and then repeat for the positive (red) sockets and firmly re-tighten.

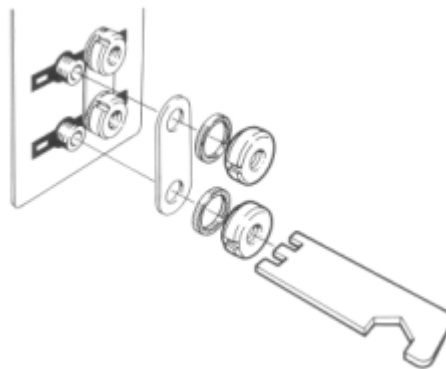

Because most amplifiers have only one speaker output you will have to double up the connection to the speaker plug - your dealer will be pleased to make up the necessary leads for you, and to set up your loudspeakers.

BI-AMPING

For ultimate performance you can go one step beyond bi-wiring and use two amplifiers, one channel for the bass and one channel for the treble. Your dealer will be pleased to effect this mode of operation for you.

MAINTENANCE/SERVICE

Linn loudspeakers require no internal maintenance and on no account should you try to remove any of the drive units, which are carefully tightened and sealed at the factory.

For servicing, always return the speakers as a pair to your supplier, using the original packing in order to reduce the risk of damage in transit, If you have lost the packaging, your supplier can provide a replacement set.

Ensure your equipment is insured by you during transit, repair, and return shipping.

GUARANTEE

These units are guaranteed under the conditions that apply in the country of purchase. To help us, please return your guarantee card.

In Addition to any statutory rights you have as a customer, we undertake to replace any parts that have failed due to faulty manufacture if you register your purchase with us.

Please keep a copy of your sales receipt as this will establish the purchase date of the loudspeakers and refer all enquiries through authorised dealers only.

LINN PRODUCTS LIMITED, FLOORS ROAD, WATERFOOT, EAGLESHAM,
GLASGOW G76 0EP, SCOTLAND. TELEPHONE: ++44 (0)141 307 7777
FACSIMILE: ++44 (0)141 644 4262.